

SMALL CRAFT – SEACOCKS AND THROUGH-HULL FITTINGS

INTERNATIONAL STANDARD:
EN ISO 9093-1 : 2018
Part 1: Metallic

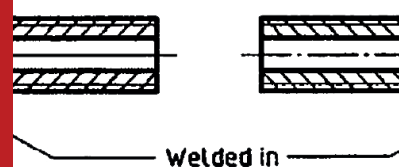
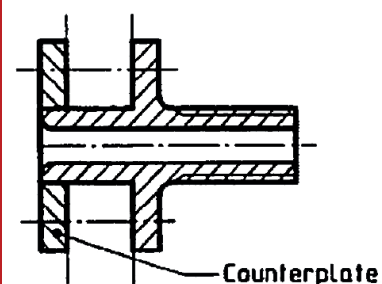
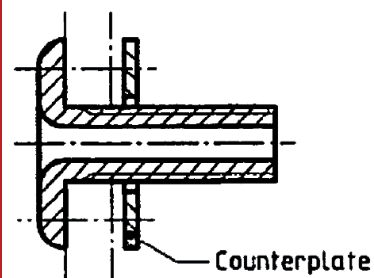
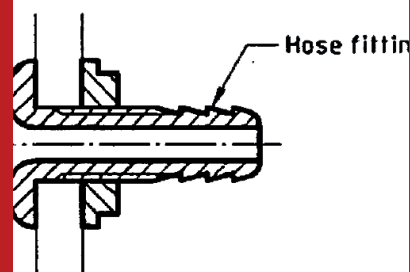
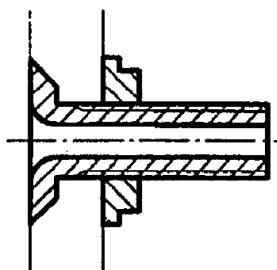
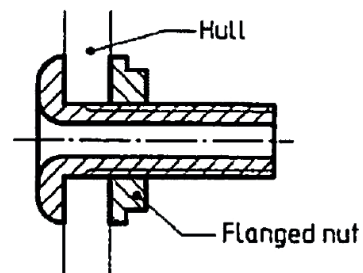

SMALL CRAFT - SEACOCKS AND THROUGH-HULL FITTINGS

Small craft - Seacocks and through-hull fittings

Part 1: Metallic

International Standard: EN ISO 9093-1 : 2018

The part 1 of ISO 9093 specifies requirements for metallic through-hull fittings, seacocks and hose fittings that specifically form part of water intake and discharge lines, and for wet exhaust outlets used in small craft of up to 24 metres length of hull. Through-hull fittings for other purposes are not covered.

Here are the main *players* of this standard and their definitions:

- **Through-hull fitting:** any fitting designed to permit passage of liquids or gases through the hull.
- **Seacock:** any valve of the ball, cylinder, plug, gate or butterfly type directly fitted to a hull or a through-hull fitting.
- **Corrosion-resistant:** material used for a fitting which, within a service time of five years, does not display any defect that will impair tightness, strength or function.
- **Protection against corrosion:** any metallic or non-metallic sheathing or coating on materials that are not corrosion-resistant such that the fitting within a service time of five years does not display any defect that will impair tightness, strength or function.
- **Readily accessible:** capable of being reached for operation, inspection or maintenance without removal of any craft structure or use of any tools or removal of any item of portable equipment stowed in places intended for storage of portable equipment such as lockers, drawers or shelves.

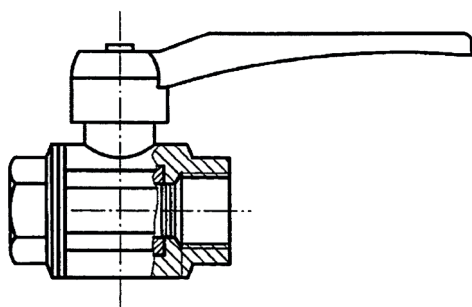



We use **materials corrosion-resistant** taking into account the various and changing materials, substances, impurities that pass through the fittings.

Let us remember, as the norm also mentions, that the combination of different materials shall take into consideration the possibility of galvanic action. Materials in contact with each other shall be galvanically compatible and shall not prevent the device from acting as intended.

We go to great lengths to do research on the materials to find and use the best alloys for nautical and hydraulic use. We have a reference study available to clarify any doubts about it.

Our **through-hull fittings** present a secure, lasting and watertight connection that cannot be dislodged by outside forces due to operating of the fitting and components attached to it, such as a seacock, and they technically comply with the standard.

Our **seacocks** are designed as to permit positive operation under any condition likely to be encountered under normal service conditions and a visual check, with a position indicator, of the open and closed position. They technically comply with the standard.

Our **hose fittings** are technically in compliance with the standard: materials, requirements and configurations.

Our products intended for the use on pleasure vessels having hull length less than 24,00 metres have been submitted to the ascertainments foreseen by the Standard ISO 9093-1 and have the constructive characteristics as per technical documentation filed at RINA Head Office.

Above the 24 meters hull length, according to the relative standards, the registration class and the kind of product and its measure, it is necessary to carry out specific tests.

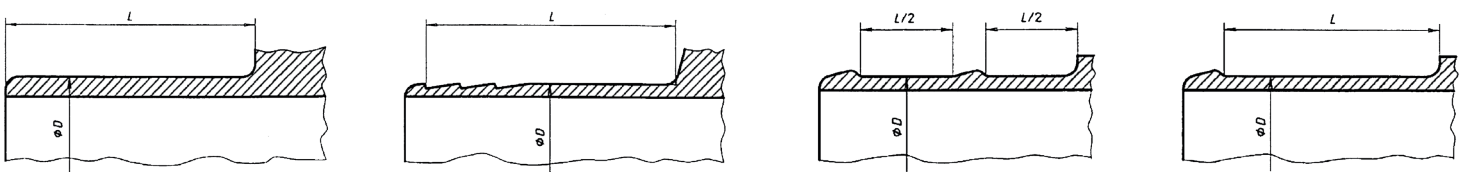

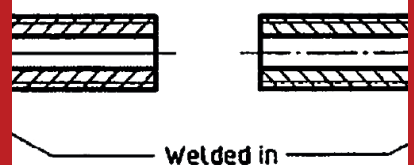
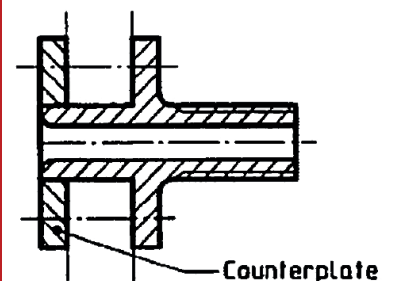
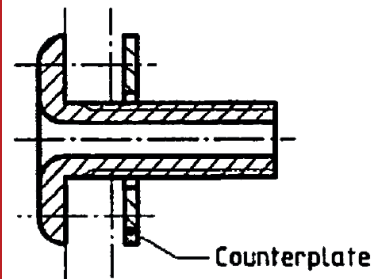
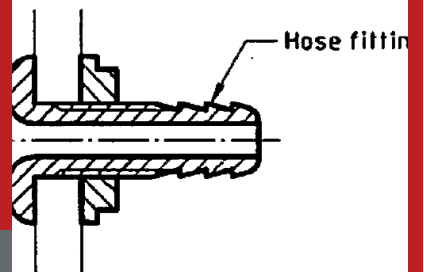
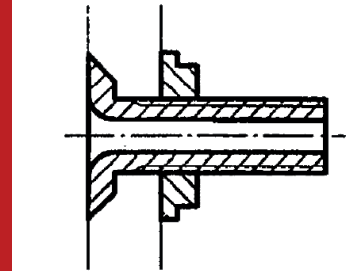
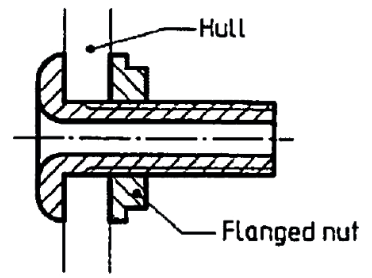

Don't forget to share your ideas with us!

 [Via delle Acacie, 2
28075 Grignasco \(NO\) - Italy](https://www.guidisrl.it)

 +39 0163 418000

 info@guidisrl.com

 <https://www.guidisrl.it>

 [guidi_srl](https://www.instagram.com/guidi_srl)

 [@guidisince1968](https://www.facebook.com/guidisince1968)

 [Guidi srl - Marine Accessories](https://www.linkedin.com/company/guidi-srl)

 [guidisrl](https://www.pinterest.com/guidisrl)

